

E. Components diagram / Parts list

Case assembly

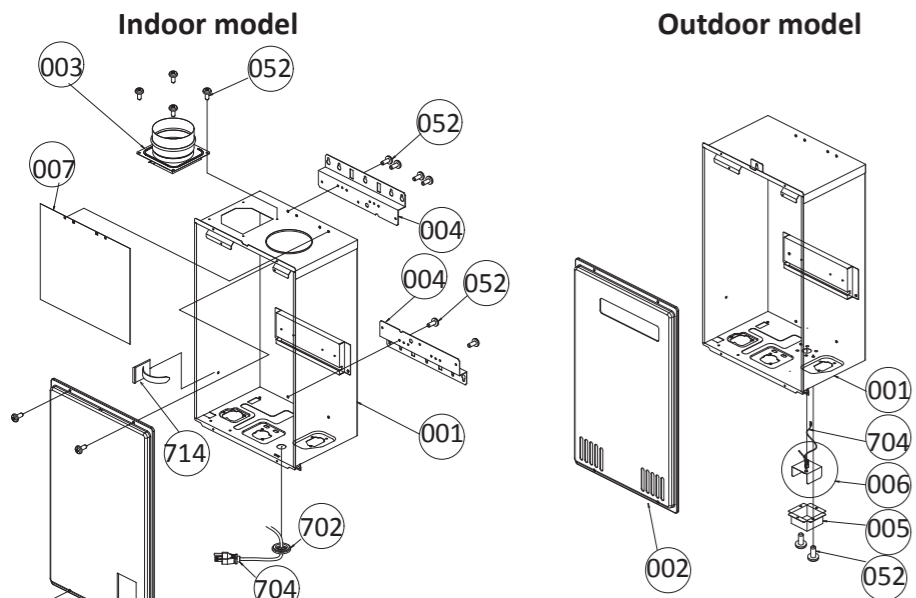

Temperature controller Indoor model

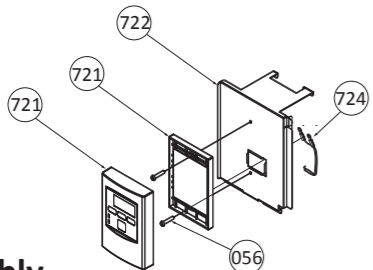

Burner assembly

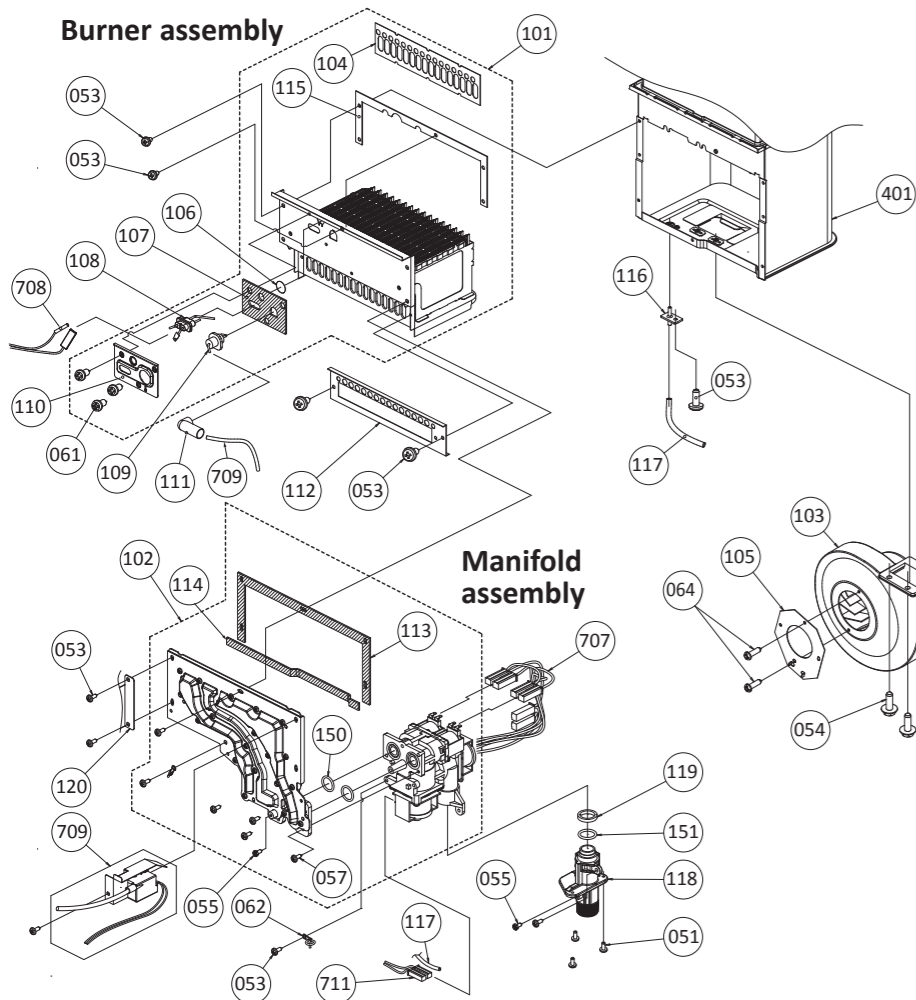

Water way assembly

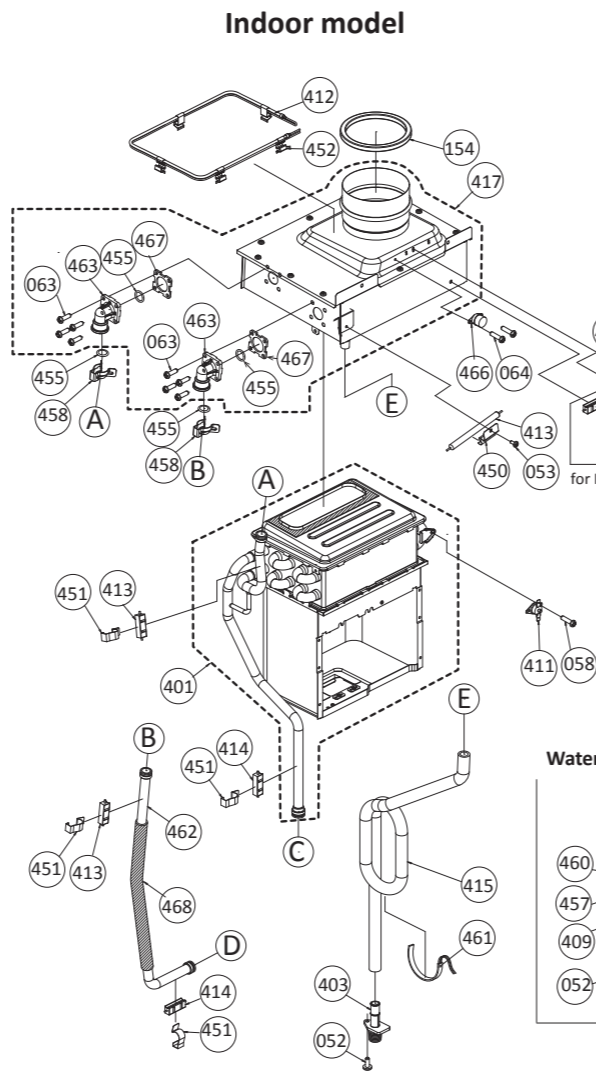

Temperature remote controller

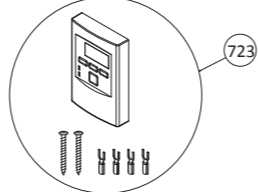

Outdoor model

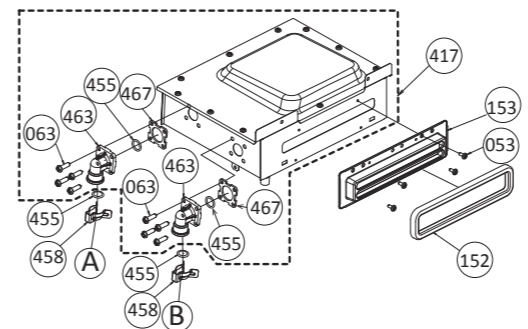

Water inlet section

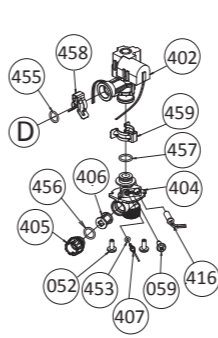

Water outlet section

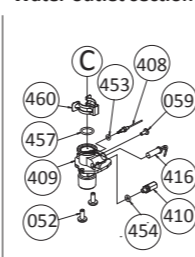

Surge box

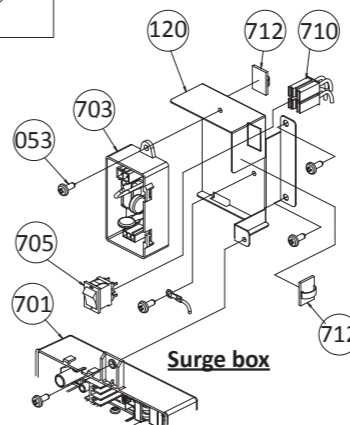

Computer board assembly

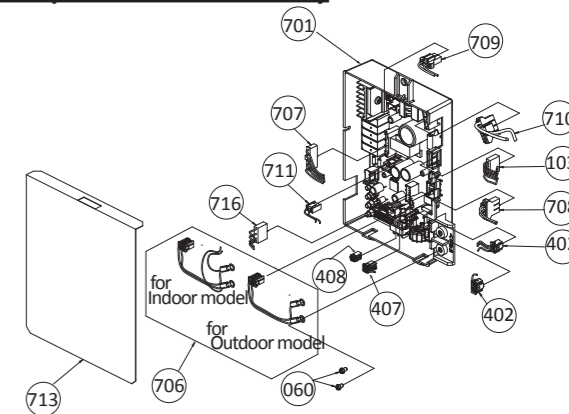

Item #	Part #		Description
	140 model	T-H3M model	
001	N/A	EK450	Case assembly for Indoor model
	N/A	EK451	Case assembly for Outdoor model
002	N/A	EK452	Front cover for Indoor
	N/A	EK453	Front cover for Outdoor
003	320273-350	EK454	Intake air port assembly
004	N/A	EK455	Bracket
005	319143-510	EK190	Junction box
006	320273-352	EK456	Power supply cord assembly
007	N/A	EK457	Back guard panel
050	319143-025	EW000	Screw M4x12 (W/Washer)
051	319143-325	EW001	Screw M4x10 (W/Washer)
052	319143-026	EW002	Screw M4x10 (Coated)
053	319143-060	EW003	Screw M4x10
054	319143-326	EW004	Hex head screw M4x12 (W/Washer)
055	319143-063	EW005	Hex head screw M4x8
056	N/A	EW018	Pan screw M4X20
057	319143-201	EKK31	Tap tight screw M4x12 FEZN
058	319143-087	EW00A	Screw M3x6 SUS
059	319143-328	EW009	Screw M4x6
060	N/A	EK191	Screw M3x6
061	319143-059	EW00D	Pan screw M4x8
062	319143-048	EM167	Wire clamp 60
063	320273-497	EW00P	Screw M4x10
064	319143-330	EW00B	Screw M3x6 SUS3

Item #	Part #		Description
	140 model	T-H3M model	
101	320273-353	EK458	Burner assembly
102	320273-354	EK459	Manifold with gas valve assembly LP
	320273-356	EK460	Manifold with gas valve assembly NA
103	319143-443	EK109	Fan motor for Indoor model
	319143-043	EKK25	Fan motor for Outdoor model
104	319143-031	EKK2X	Burner gasket
105	320273-557	EK491	Fan damper for Indoor model
	319143-282	EM381	Fan damper for Outdoor model
106	319143-033	EKK2V	Burner window
107	319143-034	EKK2W	Rod holder gasket
108	319143-517	EK193	Flame rod
109	320273-357	EK461	Igniter rod
110	319143-036	EKK32	Rod holder
111	320273-358	EK462	Rod cap
112	320273-359	EK463	Burner damper Indoor
113	320273-360	EK464	Burner damper Outdoor
	319143-044	EKK2Y	Manifold gasket A
114	319143-045	EKK2K	Manifold gasket B
115	319143-032	EKK0G	Burner holder gasket
116	319143-042	EKK2D	Pressure port
117	319143-344	EX019	Combustion chamber tube
118	320273-362	EK465	Gas inlet
119	319143-049	EKK2Z	Gas inlet ring
120	N/A	EK466	Surge box plate
150	319143-350	EZP18	O-ring P18 NBR (Black)
151	319143-057	EK042	O-ring P20 NBR (Black)
152	319143-370	EK442	Silicon ring for Outdoor model
153	319143-121	EX13J	Exhaust port for Outdoor model
154	319143-065	EKN50	Silicon ring

Item #	Part #		Description
	140 model	T-H3M model	
401	320273-556	EK467	Heat exchanger assembly for 140 Indoor and Outdoor
402	319143-463	EK129	Flow adjustment valve / Flow sensor
403	319143-018	EKH23	Condensate drain port
404	319143-193	EKK1U	Water inlet
405	319143-197	EKK2B	Inlet drain plug
406	319143-198	EKK2C	Inlet water filter
407	319143-214	EKK4J	Inlet thermistor
408	319143-529	EK207	Outlet thermistor
409	319143-466	EK104	Water outlet
410	319143-199	EKK2E	Outlet drain plug
411	319143-228	EM212	Hi-Limit switch
412	319143-067	EX02A	Overheat-cut-off fuse
413	320273-364	EK468	Pipe heater
414	320273-365	EK469	Inlet heater
415	320273-366	EK470	Drain tube
416	319143-468	EK105	Inlet heater
417	320273-553	EK471	Secondary heat exchanger for Indoor model
	320273-554	EK472	Secondary heat exchanger for Outdoor model
418	320273-367	EK473	Secondary heat exchanger heater
	N/A	EK474	Heater fixing plate
450	N/A	EK475	Pipe heater fixing plate
451	319143-125	EK031	Heater fixing plate 16
452	N/A	EK476	Fuse fixing plate
453	319143-082	EZF04	O-ring P4 FKM
454	319143-080	EZF06	O-ring P6 FKM
455	319143-100	EZF14	O-ring P14 FKM
456	319143-091	EZF15	O-ring P15 FKM
457	319143-083	EZF16	O-ring P16 FKM
458	319143-105	EKK24	Fastener "14-22"
459	319143-226	EM192	Fastener "16A"
460	319143-205	EKK39	Fastener "16-25A"
461	319143-535	EK217	Flat heater
462	320273-555	EK477	Cold pipe for 140 model
463	320273-368	EK478	Header connection
464	319143-106	EX13H	Thermistor fixing plate
465	319143-111	EX13L	Exhaust thermistor gasket
466	319143-104	EKH6G	Hi-limit switch for exhaust
467	319143-542	EKK29	Gasket
468	319143-558	EK479	Inlet pipe packing
701	320273-369	EK480	Computer board
702	319143-426	EX148	Rubber grommet
703	320273-128	EK280	Surge box
704	319143-427	EK146	120 VAC wire for Indoor model
705	319143-546	EK143	120 VAC wire for Outdoor model
	319143-141	EKK4V	120 VAC Power ON-OFF switch
706	320273-376	EK481	Remote controller wire for Indoor model
707	319143-473	EK138	Remote controller wire for Outdoor model
	320273-379	EK482	Gas valve wire
708	320273-380	EK483	Flame rod wire
709	320273-381	EK484	Igniter assembly
710	319143-185	EKJ59	Freeze protection thermostat
711	319143-481	EK112	Proportional gas valve wire
712	N/A	EX004	Nylon clamp FC6
713	319143-191	EKK1M	Computer board cover
714	319143-500	EX13C	Cable clamp for Indoor model
715	319143-131	EKH6E	Exhaust thermistor for Indoor model
716	319143-501	EK180	Exhaust Hi-limit switch wire
721	320273-684	EK487	Temperature controller for Indoor model
722	N/A	EK490	Fixing plate
723	9009069005	TM-RE42	Temperature remote controller
724	320273-512	EK489	Remote controller connection wire